

Shackles to BS 3032: 1958

This popular shackle is used throughout various industries in the UK and beyond. Predominantly used in the industrial and construction markets as a load rated lifting shackle, they are also very prevalent in marine mooring applications. As you can see from the date the standard was first introduced, they have been around for many years. By far the most popular shackle types are Dee and Bow shackles with a screw pin (type A pin), although safety pin (type E pin) versions are also available. Care needs to be taken when choosing shackles to this standard as there are many poor quality imitations currently in the market place. The faults can range from incorrect material used, lack of or incorrect heat treatment and poor manufacturing / machining processes leading to inferior quality products.

Having invested heavily in tooling, William Hackett has begun to manufacture, under licence, a core of these sizes, with sole distribution rights in the UK & Ireland. Through this manufacturing link we are able to control the material, manufacturing and all other quality control processes that give us a high quality finished product. All shackles manufactured by William Hackett comply completely with BS 3032: 1958, including correct material specification and heat treatment. The shackles that we manufacture are marked with an asterisk (*) below.

Material: BS 970 150M19

Finish: Self Colour / Hot Dipped Galvanized

Test: Batch Tested and Certified

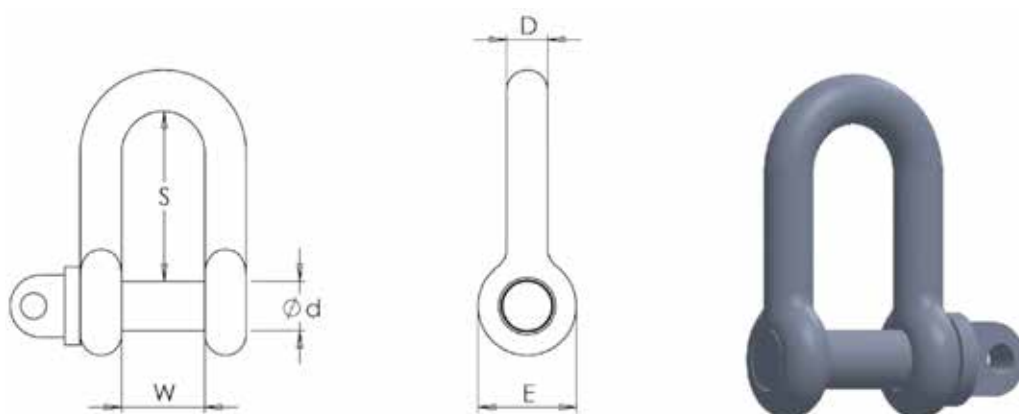

Part Code Self Colour	Part Code Galvanized	W.L.L (ton)	D (inch)	d (inch)	W (inch)	S (inch)	E (inch)	Weight ea (Kg)
NHS03206DS	NHS03206DG	0.25	1/4	3/8	1/2	1	3/4	0.06
NHS03210DS	NHS03210DG	0.50	3/8	1/2	3/4	1.1/2	1	0.16
NHS03212DS	NHS03212DG	0.75	1/2	5/8	1.1/8	2.1/8	1.1/4	0.35
NHS03216DS	NHS03216DG	1.50	5/8	3/4	1.1/4	2.1/2	1.1/2	0.63
NHS03220DS	NHS03220DG	2.00	3/4	7/8	1.1/2	2.7/8	1.3/4	1.00
NHS03222DS	NHS03222DG	3.00	7/8	1	1.3/4	3.1/4	2	1.54
NHS03225DS	NHS03225DG	3.75	1	1.1/8	2	3.3/4	2.1/4	2.21
NHS03228DS	NHS03228DG	5.00	1.1/8	1.1/4	2.1/8	4.1/8	2.1/2	3.11
NHS03232DS	NHS03232DG	6.00	1.1/4	1.3/8	2.3/8	4.1/2	2.3/4	4.33
NHS03235DS	NHS03235DG	7.00	1.3/8	1.1/2	2.5/8	5	3	5.33

Shackles to BS 3032: 1958

Material: BS 970 150M19
Finish: Self Colour / Hot Dipped Galvanized
Test: Batch Tested and Certified

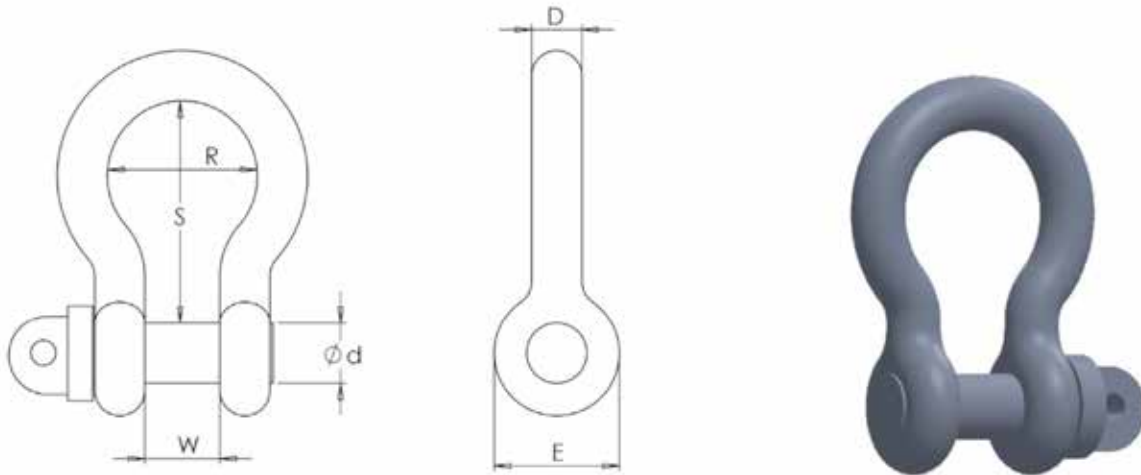

Part Code Self Colour	Part Code Galvanized	W.L.L (ton)	D (inch)	d (inch)	W (inch)	S (inch)	R (inch)	E (inch)	Weight ea (Kg)
NHS03210BS	NHS03210BG	0.45	3/8	1/2	5/8	1.5/8	1	1	0.18
NHS03212BS	NHS03212BG	0.75	1/2	5/8	7/8	2.1/8	1.1/4	1.1/4	0.34
NHS03216BS	NHS03216BG	1.25	5/8	3/4	1.1/8	2.3/4	1.5/8	1.1/2	0.65
NHS03220BS	NHS03220BG	2.00	3/4	7/8	1.3/8	3.3/8	2	1.3/4	1.08
NHS03222BS	NHS03222BG	2.75	7/8	1	1.5/8	3.7/8	2.1/4	2	1.80
NHS03225BS	NHS03225BG	3.75	1	1.1/8	1.3/4	4.1/4	2.1/2	2.1/4	2.46
NHS03228BS	NHS03228BG	4.75	1.1/8	1.1/4	2	4.7/8	2.7/8	2.1/2	3.47
NHS03232BS	NHS03232BG	5.75	1.1/4	1.3/8	2.1/4	5.3/8	3.1/4	2.3/4	4.56
NHS03235BS	NHS03235BG	7.25	1.3/8	1.1/2	2.1/2	6	3.1/2	3	6.07